

Battery Charger (EC-E6002)



The user's manual can be seen at the following link:
<https://si.shimano.com>

IMPORTANT NOTICE

- Contact the place of purchase or a distributor for information on installation and adjustment of the products which are not found in the user's manual. A dealer's manual for professional and experienced bicycle mechanics is available on our website (<https://si.shimano.com>).
- Do not disassemble or modify the product.

For safety, be sure to read this user's manual thoroughly before use, and follow it for correct use.

IMPORTANT SAFETY INSTRUCTIONS

SAVE THESE INSTRUCTIONS - This manual contains important safety and operating instructions for SHIMANO STEPS battery charger.

For replacement information, contact the place of purchase or a bicycle dealer.

Be sure to observe the following instructions in order to avoid burns or other injury from fluid leakage, overheating, fire, or explosion.

⚠ DANGER

- Do not disassemble or modify the battery charger. If this is not observed, electric shocks or injury may occur.
- Use the specified battery and battery charger combination for charging and observe the specified charging conditions. Do not charge non-rechargeable batteries. Doing otherwise may cause overheating, bursting, or ignition.
- If the battery does not become fully charged even two hours after the designated charging time, immediately unplug the battery from the electrical outlet and contact the place of purchase. Doing otherwise may cause overheating, bursting, or ignition.

- Do not allow the battery charger to get wet. If it is wet or water is allowed inside, it could cause a fire, ignition, overheating, or electric shock.

- Do not use it while it is wet, and do not touch or hold it with wet hands. An electric shock may occur.

- Do not use the battery charger when it is covered with a cloth or other material. Doing otherwise may cause the heat to build up and the case may become deformed, or fire, ignition, or overheating may occur.

- Use the battery charger at the specified power supply voltage only. If a power supply voltage other than that specified is used, fire, destruction, smoke, overheating, electric shocks or burns may occur.

⚠ DANGER - TO REDUCE THE RISK OF FIRE OR ELECTRIC SHOCK, DO NOT USE THIS CHARGER OUT OF U.S.A. AND CANADA.

(This clause applies to users in North America only)

⚠ WARNING

- Be sure to hold the power plug when connecting or disconnecting from the electrical outlet. Failure to do so may cause a fire or electric shock. If the following symptoms are observed, stop using the device and contact the place of purchase. A fire or electric shock may be caused.
 - Heat, acrid-smell, or smoke is coming out from the power plug.
 - There may be a bad connection inside the power plug.
- Do not touch the metallic parts of the device or the power plug on the AC adapter or other parts if there is a lightning storm. If lightning strikes, electric shocks may occur.
- Do not overload the electrical outlet with appliances beyond its rated capacity, and use only a 100 - 240 V AC electrical outlet. If the electrical outlet is overloaded by connecting too many appliances using adapters, overheating resulting in fire may occur.
- Do not damage the power cord or power plug. (Do not damage, modify, forcibly bend, twist or pull it, put it near hot objects, place heavy objects on it or bundle it tightly together.) If it is used while damaged, fire, electric shocks or short-circuits may occur.
- Do not use the battery charger with commercially-available electrical transformers designed for overseas use (travel converters). They may damage the battery charger.
- Always be sure to insert the power plug as far as it will go. If this is not observed, fire may occur.
- Do not insert or remove the plug while it is wet. Doing so may result in electric shock. If the inside of the plug is wet, dry it thoroughly before inserting it.

- Do not recharge the battery in wet or very humid places, or outdoors. A fire, ignition, overheating, or electric shock may occur.
- When charging the battery while it is installed on the bicycle, do not move the bicycle. The battery charger's power plug may come loose and not be fully inserted into the electrical outlet, resulting in a risk of fire.

⚠ CAUTION

- Periodically check the battery charger and adapter, particularly the cord, plug, and case, for any damage. If the battery charger or adapter is broken, do not use it until it has been repaired by the place of purchase or a distributor.

- Use the product under the supervision of someone responsible for safety, and only as instructed. Do not allow anyone (including children) with reduced physical, sensual, or mental capacity, or those without experience or knowledge, to use the product. Do not allow children to play near the product.

- When performing cleaning, disconnect the power plug from the electrical outlet and the charging plug from the battery. If this is not observed an electric shock may occur.
- Do not touch the battery charger when it is at a high temperature. Doing so may cause a burn.
- Do not touch the battery charger for an extended period of time when its temperature has increased. Doing so may cause a low-temperature burn.
- The temperature of the product may reach 40 to 70°C while charging, but this is normal.
- Before using battery charger, read all instructions and cautionary markings on battery charger, battery, and product using battery.

Notice

Charge the battery indoors to avoid exposure to rain or wind.

- The battery can be charged at temperatures between 0 - 40°C. The battery charger will not operate at temperatures outside the range. It will display an error. (The battery charger LED lamp flashes.)
- Do not use outdoors or in environments with high humidity.
- Do not place the battery charger on dusty floors when using it.
- Place the battery charger on a stable surface such as a table when using it.
- Do not place any objects on top of the battery charger or its cable. Also, do not cover it with a cover or other object.
- Do not bundle the cables.
- Do not hold the battery charger by the cables when carrying it.
- Do not apply excessive tension to the cable and charging plug.
- In order to prevent the cable from being damaged, avoid wrapping it around the main body during storage.
- Do not wash the battery charger or wipe it using detergents.
- Do not allow children to play near the product.

- When charging with the battery installed to a bicycle, take care that your legs, etc. do not get caught in the battery charger cord. Doing so may cause injury or cause the bicycle to fall over and break the components.
- When charging the battery while it is mounted on the bicycle, be careful of the following:
 - Do not remove the battery from the battery mount while charging.
 - Do not ride with the battery charger mounted.
- Make sure to close the charging port cap after charging is complete. If foreign material such as dirt or dust is adhering to the charging port, it may not be possible to insert the charging plug.
- Products are not guaranteed against natural wear and deterioration from normal use and aging.
- For maximum performance we highly recommend SHIMANO lubricants and maintenance products.

Charging can be carried out at any time, regardless of the remaining battery, but please fully charge the battery in the following case:

- The battery is not fully charged at the time of purchase. Before riding, be sure to fully charge the battery.

When the battery is completely depleted, charge it as soon as possible. If you leave the battery without charging it, the battery will deteriorate and may become unable to be used.

- If the bicycle will not be ridden for an extended period, store it with a battery level of approximately 70%. Also, charge the battery once every six months to ensure that it is not completely discharged.
- Using the battery outside the operating temperature range may cause problems with operation or performance degradation.
- The charging time is longer when the battery temperature is high. Also, read the SHIMANO STEPS user's manual.

■ Main specifications

Input	AC 100 - 240 V, 1.5 A, 50 / 60 Hz	
Output	DC 42 V, 1.8 A	
Compatible batteries*	Battery type	Li-Ion
	Nominal capacity	SHIMANO BT-EN404 / BT-EN604 / BT-E6000 / BT-E6010 / BT-E8014: 11.6 Ah BT-EN405 / BT-EN605 / BT-EN805 / BT-EN805-L / BT-E6001 / BT-E8010 / BT-E8020 / BT-E8035 / BT-E8035-L: 14 Ah BT-EN606 / BT-EN806 / BT-E8016 / BT-E8036: 17.5 Ah
	Nominal voltage	36 V

*Includes batteries that may not be usable in your region.

Names of parts

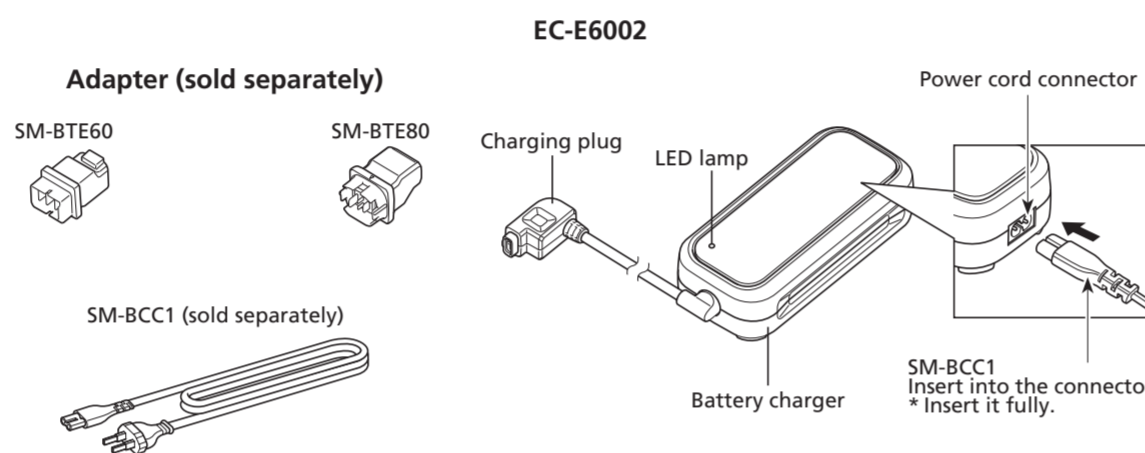

Charging method

■ Charging the battery removed from the bicycle

Charge the battery placed on a level surface indoors.

When charging, orient the battery and the battery charger as indicated in the figure.

*The orientation of the battery charging port differs according to the model.

BT-EN404 / BT-EN405 / BT-EN805 / BT-EN805-L / BT-EN806 / BT-E6000 / BT-E6001 / BT-E6010 / BT-E8035 / BT-E8035-L / BT-E8036

- Attach the adapter to the battery charger's charging plug.
- Connect the battery charger's power plug to the electrical outlet.
- Insert the adapter into the battery's charging port.

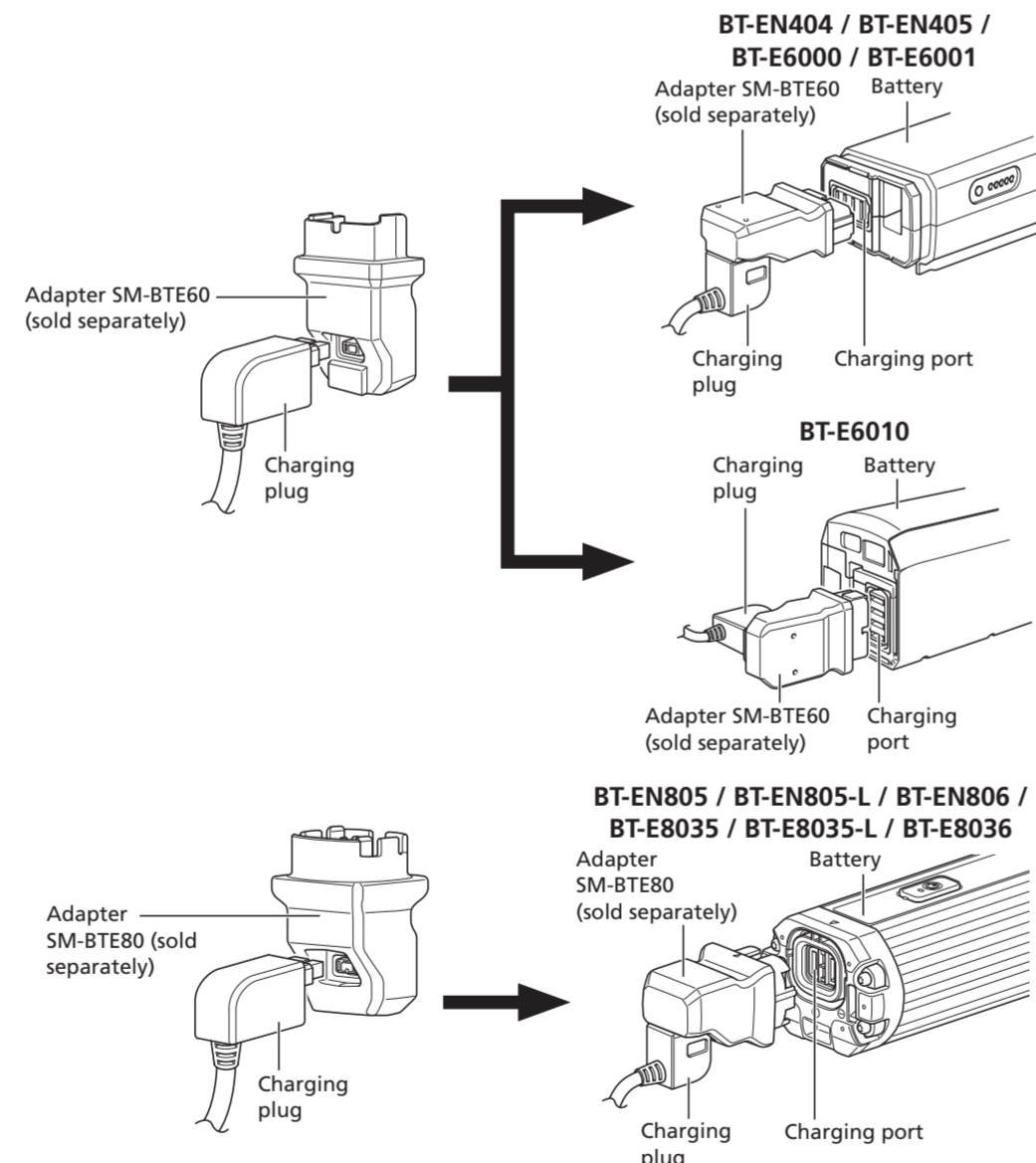

BT-EN604 / BT-EN605 / BT-EN606 / BT-E8010 / BT-E8014 / BT-E8016 / BT-E8020

- Connect the battery charger's power plug to the electrical outlet.
- Insert the charging plug into the battery's charging port.

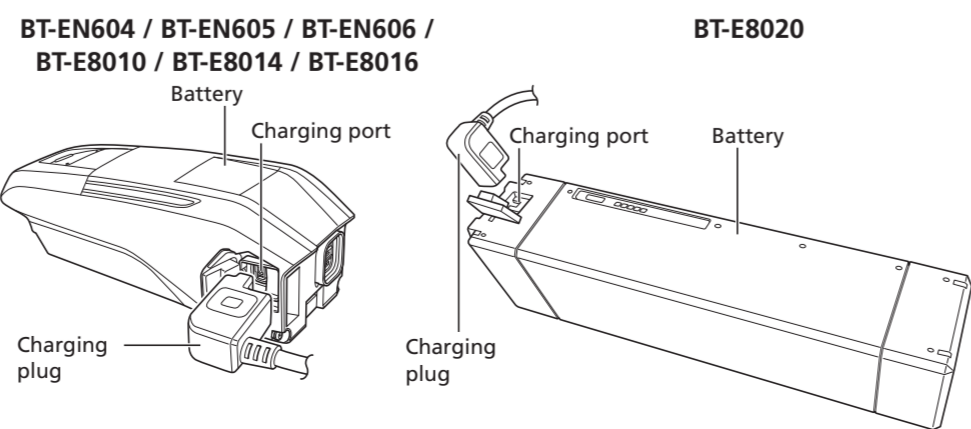

■ Charging the battery attached to the bicycle

Charge the battery with the battery charger placed on the ground or some other stable surface. Fix the bicycle in place when charging, so that it does not tip over.

- Connect the battery charger's power plug to the electrical outlet.
- Insert the charging plug into the charging port.

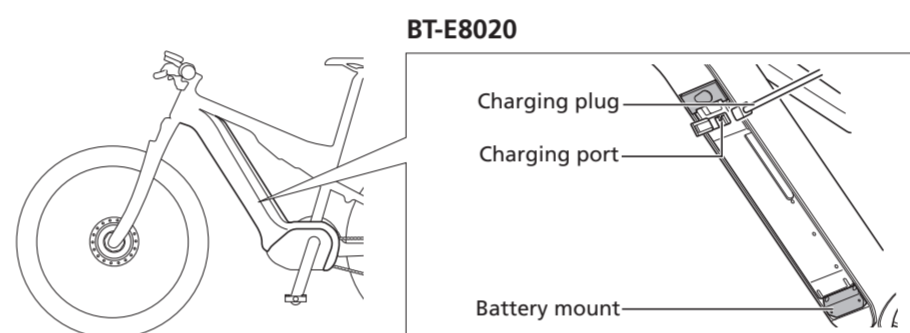
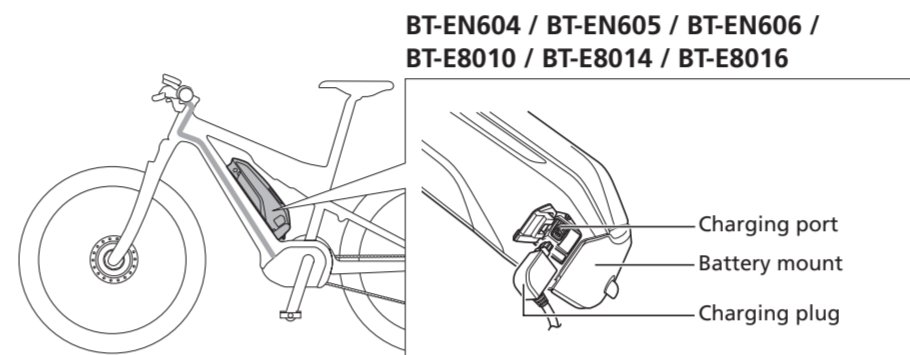
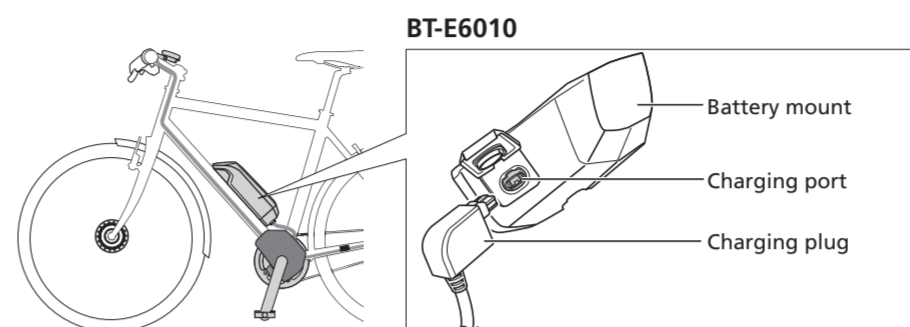
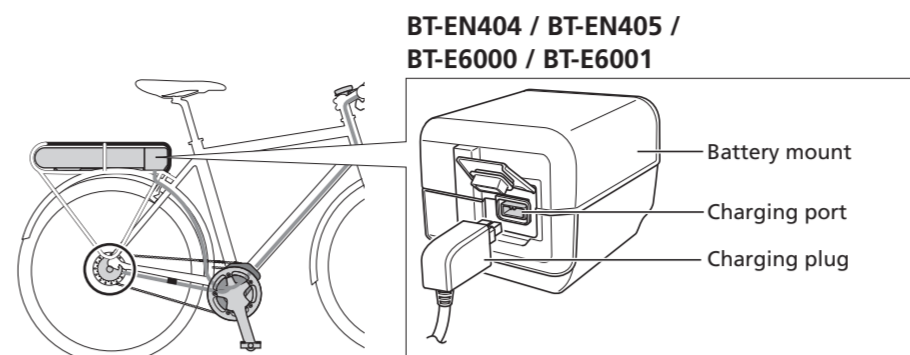

BT-EN805 / BT-EN805-L / BT-EN806 / BT-E8035 / BT-E8035-L / BT-E8036

- The position of the satellite charging port differs depending on the frame design.

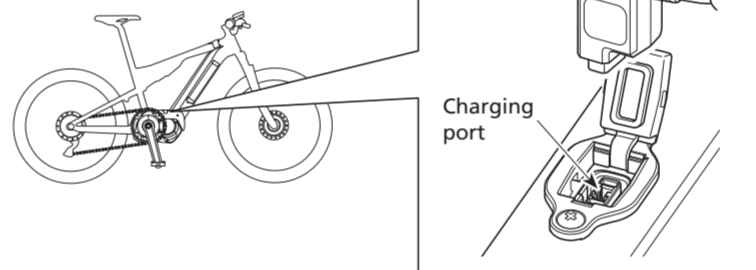

■ Charger LED lamp

- After charging has started, the LED lamp on the battery charger lights up.

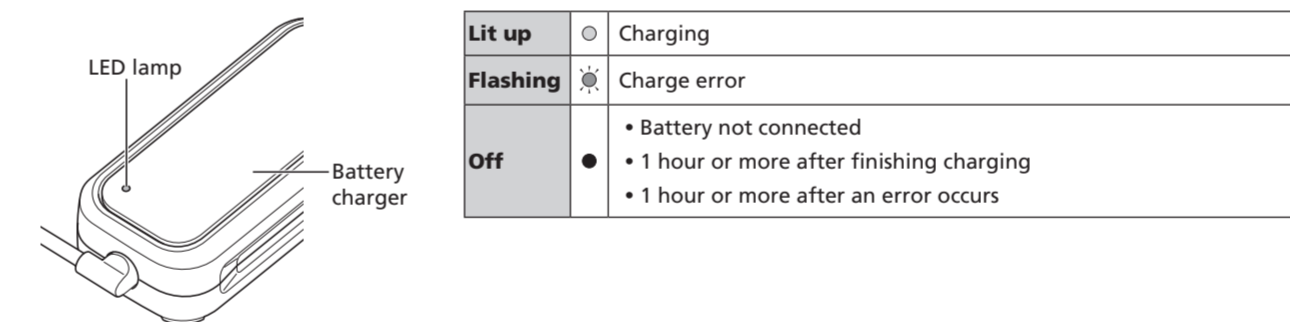

Lit up	○	Charging
Flashing	⚡	Charge error
Off	●	• Battery not connected
	●	• 1 hour or more after finishing charging
	●	• 1 hour or more after an error occurs

- For information on the charging time, refer to the following.

Designated charging time	
Battery	Charging time from a battery level of 0%
BT-EN404 / BT-EN604 / BT-E6000 / BT-E6010 / BT-E8014	Approximately 6 hours and 30 minutes
BT-EN405 / BT-EN605 / BT-EN805 / BT-EN805-L / BT-E6001 / BT-E8010 / BT-E8020 / BT-E8035 / BT-E8035-L	Approximately 7 hours and 30 minutes
BT-EN606 / BT-EN806 / BT-E8016 / BT-E8036	Approximately 10 hours and 12 minutes

Troubleshooting

The FAQ for SHIMANO STEPS can be accessed with the following:



<https://si.shimano.com/FAQ/STPOA>

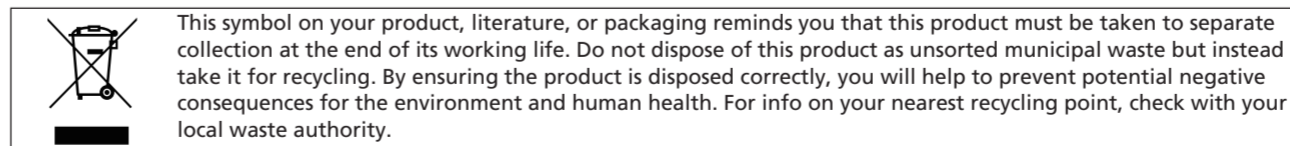

This device complies with part 15 of the FCC Rules. Operation is subject to the following two conditions:

(1) This device may not cause harmful interference, and (2) this device must accept any interference received, including interference that may cause undesired operation.

NOTE: This equipment has been tested and found to comply with the limits for a Class B digital device, pursuant to part 15 of the FCC Rules. These limits are designed to provide reasonable protection against harmful interference in a residential installation. This equipment generates, uses and can radiate radio frequency energy and, if not installed and used in accordance with the instructions, may cause harmful interference to radio communications. However, there is no guarantee that interference will not occur in a particular installation. If this equipment does cause harmful interference to radio or television reception, which can be determined by turning the equipment off and on, the user is encouraged to try to correct the interference by one or more of the following measures:

- Reorient or relocate the receiving antenna.
- Increase the separation between the equipment and receiver.
- Connect the equipment into an outlet on a circuit different from that to which the receiver is connected.
- Consult the dealer or an experienced radio/TV technician for help.

SHIMANO

SHIMANO NORTH AMERICA BICYCLE, INC.
 One Holland, Irvine, California 92618, U.S.A. Phone: +1-949-951-5003

SHIMANO EUROPE B.V.
 High Tech Campus 52, 5556 AG Eindhoven, The Netherlands Phone: +31-402-612222

MADISON (A DIVISION OF H.YOUNG (OPERATIONS) LTD)
 Roebuck Way, Knowlhill, Milton Keynes, Buckinghamshire, MK5 8RL, United Kingdom

SHIMANO INC.
 3-77 Oimatsu-cho, Sakai-ku, Sakai City, Osaka 590-8577, Japan

Please note: specifications are subject to change for improvement without notice. (English)
 © Sep. 2022 by SHIMANO INC. ITP

CE UK